

AVAL B006

Smart shut-off module
with M-Bus controlled ball valve



Wired M-Bus protocol



Integrated valve



Long battery life



Easy installation



Remote and local valve control



Robust casing (IP 65)



Integration with 3rd party management systems



Designed for different valve sizes
(from DN15 to DN32)

Control the water supply with **AVAL B006** by AIUT. A perfect solution that can help district cooling companies to shut down the cooling water supply for a certain period. This valve module is designed for opening and closing the valve through M-Bus and can be easily managed remotely.

AVAL B006 is a precision-engineered device with a replaceable battery that guarantees ultra-low consumption. Its compact design together with the simple and optimized installation makes it one of the best solutions that will optimize your work and keep a balance between operational costs and top-quality service.

Plug & play installation

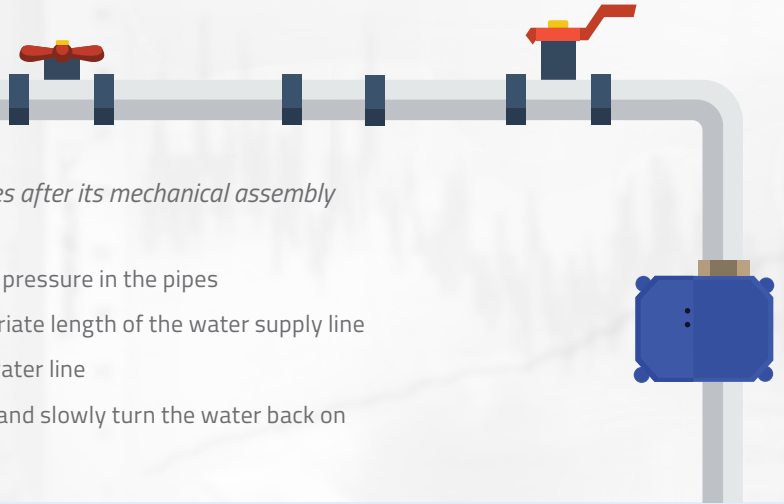

Enjoy the full functionality of the device a mere minutes after its mechanical assembly

- Shut off the water supply and make sure to relieve pressure in the pipes
- Measure the assembled device and cut the appropriate length of the water supply line
- Connect and hand tighten the device to the main water line
- Once installed, cable connect the device to M-Bus and slowly turn the water back on
- Check the status of the valve (see below)

Communication

- Communication technology: M-Bus protocol + proprietary extension (details in separate M-Bus Protocol description)
- Connection: 1m, two wire M-Bus cable
- Baud rate: configurable
- Read data: open/close valve, valve status

Power supply

- Replaceable, lithium battery
- 10 year lifetime (for valve operation twice per month)

Environmental parameters

- Operating temperature: -5°C to +60°C
- IP 65

HMI Interface

- Magnetic "button"
- Valve status LEDs

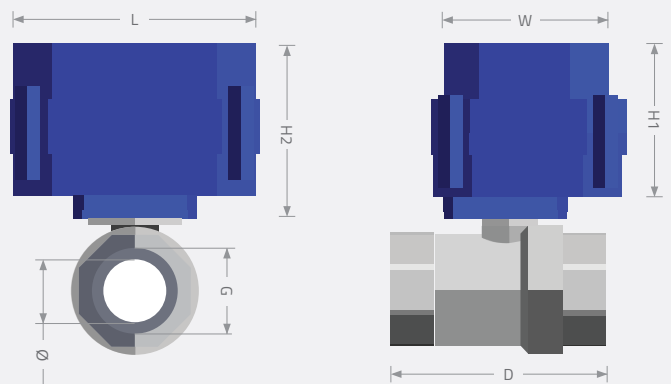

AVAL B006 versions & mechanical*

Device order no.	DN	G	Ø	L	W	H1	H2	D	Wt[g]
AVAL B006-0000	15	1/2"	15	68	54	46	56	56	390
AVAL B006-0100	20	3/4"	15	68	54	46	56	60	390
AVAL B006-0200	25	1"	20	82	62	50	58	73	700
AVAL B006-0300	32	1 1/4"	25	82	62	50	58	79	780

*All sizes in mm unless stated otherwise

HMI Interface

- Attach the magnet for 1-4s to the place indicated on the cover to check the current status of the valve (green LED solid - valve open, red LED solid - valve closed)
- The valve can be controlled manually*. For details, scan the QR code.

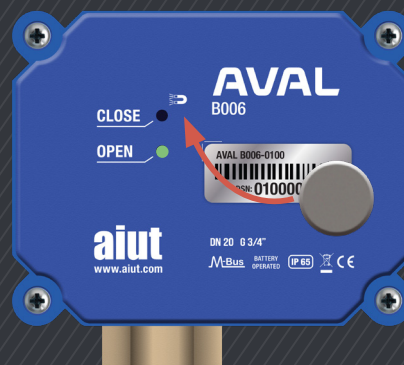

*The option of the manual valve control can be disabled remotely by an authorised user.